

LARGE ELECTRIC WALKIE PALLET JACK



TAKE A LOAD OFF

- ▶ 6000 lb. Capacity
- ▶ Ergonomic Multifunction Control Handle
- ▶ Regenerative Braking
- ▶ Galvanized Option



8HBW30

HEAVY LOADS, DELIVERED

THE TOYOTA LARGE ELECTRIC WALKIE. Power and maneuverability to handle heavy loads. Ergonomic design to maximize operator effectiveness through long shifts. The Large Electric Walkie makes loading and unloading products and traveling short distances in your warehouse or distribution center comfortably efficient and productive. Goods, delivered. Job, well done.

UP TO **3.7** MPH
TRAVEL SPEED
WITH FULL LOAD

LARGE ELECTRIC WALKIE ADVANTAGES

- ▶ **MULTIFUNCTION CONTROL HANDLE** with ergonomically positioned handgrips, dual thumbwheels, and lift, lower, and horn buttons for simplified operation of all controls with either hand
- ▶ **AC DRIVE MOTOR** plus regenerative braking for longer run time and increased productivity
- ▶ **PROGRAMMABLE PERFORMANCE PARAMETERS** customizable through a digital display to adjust for a variety of job applications
- ▶ **BOX RAIL FORK CONSTRUCTION** provides torsional rigidity and maximum strength
- ▶ **SOLID STEEL PULL RODS** add strength throughout the entire length of forks, and are much less likely to bend or flex than push rods, resulting in less maintenance
- ▶ **SELF-DIAGNOSTICS** simplify troubleshooting and eliminate the need for an external hand-held analyzer
- ▶ **GLANCE & GO DISPLAY** provides a quick summary of key information



UP TO **6000** LB.

CAPACITY



LARGE ELECTRIC WALKIE PALLET JACK

CAPACITY
6000 LBS.

FORK SIZE
32 - 60 IN.

OVERALL FORK WIDTH
22 - 27 IN.

INDUSTRIES



Beverage



Cold Storage



Distribution



Food Storage



General
Manufacturing



General
Warehousing



Retail

STANDARD FEATURES

PERFORMANCE

- AC drive motor with thermal protection & current limiting
- 24-Volt electrical system
- 6" lift
- Fault code memory with hour meter reading
- Regenerative braking
- Programmable performance
 - Adjustable maximum speed
 - Adjustable acceleration
- On/off key switch
- Lift limit switch
- Multiple hour meter indicator
- Battery discharge indicator with lift interrupt
- Fused control & power circuits
- Hydraulic overload protection valve
- Dual 1.25"-dia. lift cylinders

DURABILITY

- Control Area Network (CAN-bus) communications
- Welded construction with reinforced heavy-duty bumper
- Powder coat paint finish
- Box rail fork construction
- Steel bulkhead wrappers
- Forged rectangular steel tension rods
- Heavy-duty bushings & pins
- Solid trail fork casting (ductile iron)
- Tapered fork tips with pallet entry slides
- Four-point lift linkage
- High-strength polymer service cover
- Rubber drive tire
- Hall-effect switches

ERGONOMICS

- Multifunction control handle with ergonomically angled handgrips & wrap-around hand guard
- Dual thumbwheels for directional control & travel speed
- Intuitively positioned lift/lower buttons
- Low-effort control handle

SERVICEABILITY

- AC drive motor (no brushes or commutator)
- Self-adjusting electric disc brake
- One-piece, lightweight service access cover
- Error indicator with self-diagnostics
- Teflon[®]-coated PolyLube™ lift linkage bushings (maintenance free)

SUPPORT

- Wrap-around hand guard
- Spring-loaded control handle
- Runaway protection
- Side stabilizer steel bars
- Electric horn
- Directional reverse switch on control handle

BODY/EXTERIOR DESIGN

- SB-175 battery connector (gray)

OPTIONAL EQUIPMENT

- 48," 60" and 72" load backrest extension
- Electronic travel alarm (forward & reverse)
- Controller splash guard
- Keyless on/off switch
- Power hookup for onboard terminal (24-Volt, 2 amp)
- Power hookup for onboard terminal (24-Volt, 10 amp)
- Electronic touchpad, keyless entry system with password protection
- Pallet entry/exit rollers (single length pallet forks only 36"- 60")
- Storage tray, load backrest mounted
- Storage tray, battery compartment mounted
- Storage tray & stretch wrap holder, load backrest mounted
- Lubrication package for pivot points (grease fittings)
- Steering bearing, greaseable
- Battery compartment rollers with dual side gates
- Battery side gate interlock switches
- 13.44"-wide battery compartment
- Battery spacer kit
- Polyurethane drive tire
- Non-marking rubber drive tire
- Heavy-duty load wheels (Vulkollan®)
- Load wheel debris diversion device
- Polyurethane load wheels (tan durometer 95)
- Load wheels, single axle/dual
- Load wheels, single axle/triple
- Cold storage conditioning
- Galvanized chassis
- Galvanized chassis with cold storage
- Special paint color, complete truck
- UL-approved model type "E"
- UL-approved model type "EE"

Please contact your local, authorized Toyota Dealer for a complete list of available options.



TRUCK SPECIFICATIONS

GENERAL DATA			MODEL NUMBER			
GENERAL DATA			8HBW30			
Load Capacity	lb (kg)		6000 (2725)			
Power Type			Battery			
Operator Position			Walkie			
Tire Type	Drive / Load		Rubber / Polyurethane			
Wheels (x = driven)	Front / Rear		1 Drive / 2 Load			
EXTERIOR DIMENSIONS			8HBW30			
A Fork Width	in (mm)		9 (229)			
B Overall Fork Width	in (mm)		22 (559) or 24 (610) or 27 (686)			
C Fork Height	Lowered	in (mm)	3.25 (83)			
	Raised	in (mm)	9.25 (235)			
E Fork Lift	in (mm)		6 (152)			
F Fork Length	in (mm)	32 (813)	36 (914)	42 (1067)	48 (1220)	60 (1524)
G Overall Width	in (mm)		32.5 (826)			
H Overall Length	in (mm)	63.7 (1618)	67.7 (1720)	73.7 (1872)	79.7 (2024)	91.7 (2329)
I Wheelbase	Lowered	in (mm)	46.5 (1181)	50.5 (1283)	56.5 (1435)	62.5 (1588)
	Raised	in (mm)	41.8 (1062)	45.8 (1163)	51.8 (1316)	57.8 (1468)
J						69.8 (1773)
K Turning Radius	in (mm)	51.4 (1306)	55.4 (1407)	61.4 (1560)	67.4 (1712)	79.4 (2017)
Gross Weight Without Battery	lb (kg)	1000 (454)	1014 (460)	1036 (470)	1058 (480)	1108 (503)
L Head Length	in (mm)		32.1 (815)			
M Power Unit Height	in (mm)		31.4 (798)			
N Overall Height	in (mm)		56.7 (1440)			
O Distance from Control Handle to Floor (lowered position)	in (mm)		31.2 (792)			
P Distance from Bumper to Center of Drive Tire	in (mm)		9.6 (244)			
Q Bumper Underclearance	in (mm)		4.75 (121)			
R Bumper Height	in (mm)		9.75 (248)			
PERFORMANCE DATA			8HBW30			
Speeds	Full Load	mph (km/h)	3.7 (6.0)			
	No Load	mph (km/h)	3.7 (6.0)			
Gradeability	Full Load	%	10			
	No Load	%	10			
TIRES			8HBW30			
Tires	Number	Front / Rear	1 / 2			
	Size (dia. x width)	Drive (front)	in (mm)	12 x 4.75 (305 x 121)		
		Load (rear)	in (mm)	3.25 x 5.91 (83 x 150)		
		Stabilizers		Steel		
POWER SYSTEM			8HBW30			
Battery	Voltage/Capacity	V / Ah	Standard	24 / 510	Optional	24 / 750
	Connector (Color)			SB-175 (gray)		
	Connector Cable Location			B		
	Connector Cable Length	in (mm)		18 (457)		
Battery Compartment	Width	in (mm)		31.5 (800) ¹		
	Length	in (mm)	Standard	9.20 (234)	Optional	13.44 (341)
	Height	in (mm)		-		
Battery Weight	Maximum	lb (kg)	Standard	1056 (480)	Optional	1500 (680)
	Minimum	lb (kg)	Standard	980 (445)	Optional	980 (445)
Electric Motors	Drive (60 minutes)	hp (kW)		5.5 (4.1)		

¹ Length = 30.25" (768 mm) when equipped with optional Battery Compartment Rollers.
 NOTE: Exterior dimensions have been given for a standard model with a 9.20"-wide (234 mm) battery compartment.

EXTERIOR DIMENSIONS

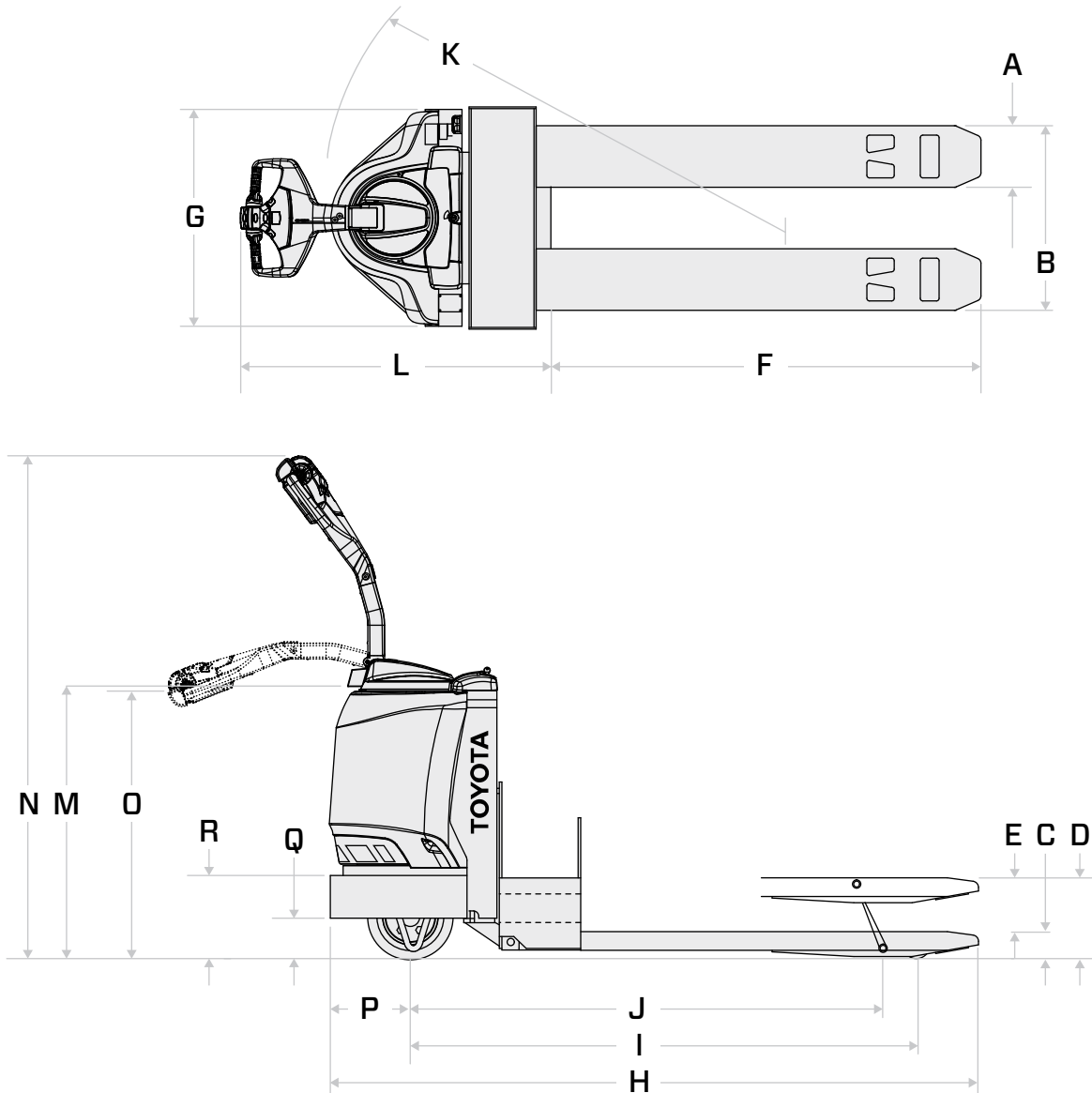

RIGHT-ANGLE STACKING AISLE REQUIREMENTS

FORK LENGTH	PALLET LENGTH	PALLET WIDTH						
		30 (762)	32 (813)	36 (914)	40 (1016)	42 (1067)	44 (1118)	48 (1220)
in (mm)	in (mm)	in (mm)	in (mm)	in (mm)	in (mm)	in (mm)	in (mm)	in (mm)
8HBW30								
32 (813)	32 (813)	65.2 (1656)	65.2 (1656)	65.2 (1656)	65.2 (1656)	65.2 (1656)	65.2 (1656)	65.2 (1656)
36 (914)	36 (914)	69.2 (1758)	69.2 (1758)	69.2 (1758)	69.2 (1758)	69.2 (1758)	69.2 (1758)	69.2 (1758)
42 (1067)	42 (1067)	75.2 (1910)	75.2 (1910)	75.2 (1910)	75.2 (1910)	75.2 (1910)	75.2 (1910)	75.2 (1910)
48 (1220)	48 (1220)	81.2 (2063)	81.2 (2063)	81.2 (2063)	81.2 (2063)	81.2 (2063)	81.2 (2063)	81.2 (2063)
60 (1524)	60 (1524)	93.2 (2367)	93.2 (2367)	93.2 (2367)	93.2 (2367)	93.2 (2367)	93.2 (2367)	93.2 (2367)

Minimum Aisle Width for Right-Angle Stacking
 Includes 4" (102 mm) clearance on each side of load.
 Add a minimum of 12" (305 mm) for easy maneuvering.



“THE NAME ON MY SHIRT SAYS TOYOTA, BUT I WORK FOR YOU.”

Alan – 360 Technician, Atlas Toyota Material Handling, Chicago, IL



HELP IS ALWAYS HERE WITH TOYOTA 360 SUPPORT.

The industry’s best and most comprehensive dealer network quickly delivers Toyota Certified Technicians to your work site. These specially trained technicians can also help assess your warehouse and facility needs to recommend the right equipment for the job. And with the largest fleet of used and rental material handling products, Toyota 360 keeps your business running at full speed.

ToyotaForklift.com/360-Support



YOUR BUSINESS IS RIDING ON IT.

Some product features described herein are optional. Please consult your dealer for specifications. Details of specifications and equipment are based on information available at time of printing and may change without notice.

